



# SUNDOR 5000 SLIDING GLASS DOOR "Small MISSILE IMPACT"

### GENERAL NOTES

1. This product has been evaluated and is in compliance with the 2010 Florida Building Code (FBC) structural requirements excluding the "High Velocity Hurricane Zone".
2. Product anchors shall be as listed and spaced as shown on details. Anchor embedment to base material shall be beyond wall dressing or stucco.
3. When installed greater than 30 feet above grade in areas requiring wind borne debris protection this product complies with Section 1609.1.2 of the 2010 FBC and does not require an impact resistant covering. This product meets missile level "A" and includes Wind Zone 4 as defined in ASTM E 1996 and Section 1609.1.2.4 of the FBC.
4. When installed 30 feet or less above grade in areas requiring wind borne debris protection this product must be protected with an impact resistant covering that complies with section 1609.1.2 of the 2010 FBC.
5. Site conditions that deviate from the details of this drawing require further engineering analysis by a licensed engineer or registered architect.

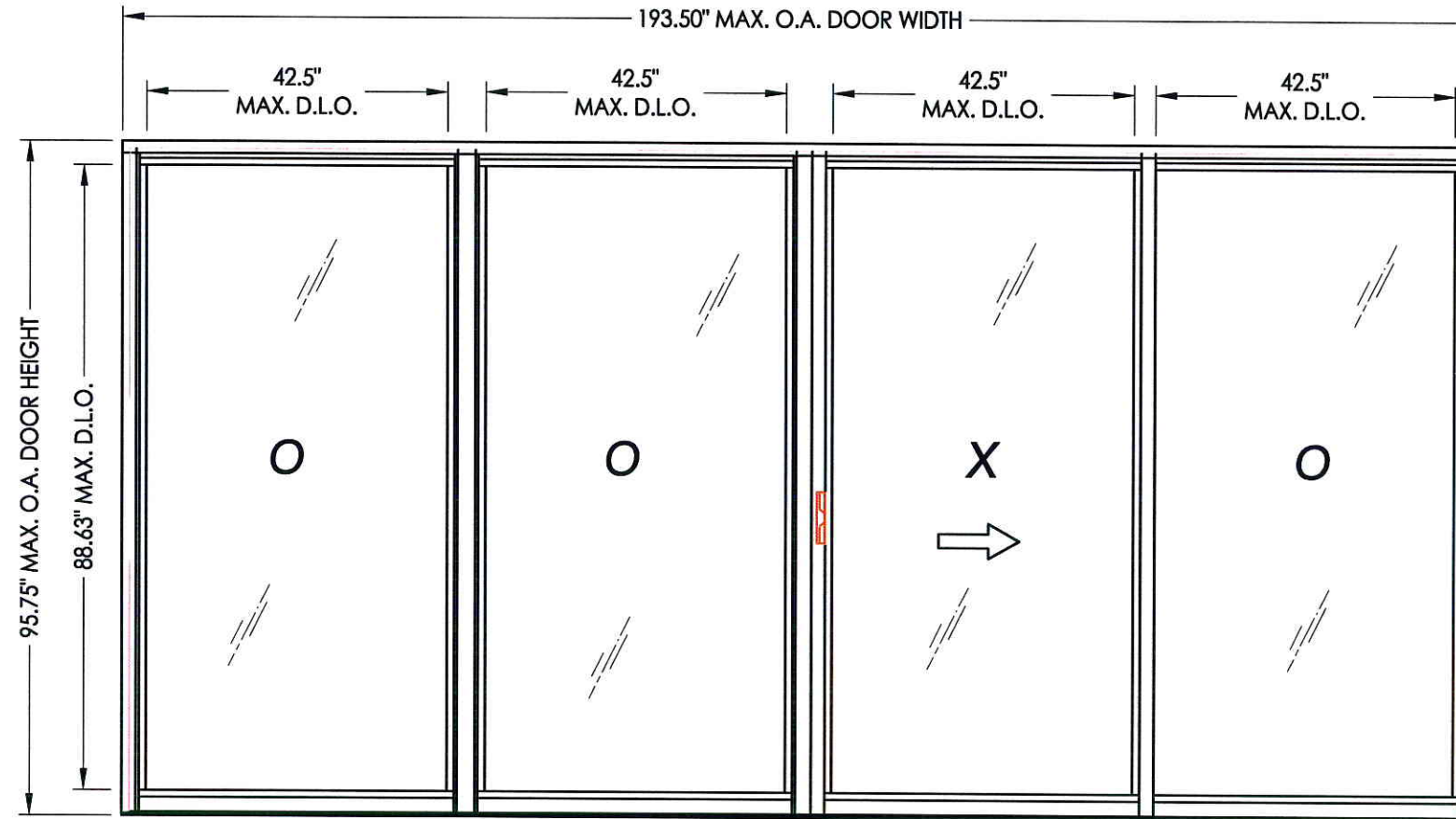

TABLE OF CONTENTS	
SHEET #	DESCRIPTION
1	TYPICAL ELEVATIONS, DESIGN PRESSURES & GENERAL NOTES
2	DOOR PANEL SECTIONS
3	DOOR PANEL SECTIONS
4	SIDELITE PANEL SECTIONS
5	CORNER DETAILS
6	HORIZONTAL CROSS SECTIONS
7	HORIZONTAL CROSS SECTIONS
8	VERTICAL CROSS SECTIONS
9	ANCHORING - CONCRETE SUBSTRATE
10	ANCHORING - STEEL SUBSTRATE
11	COMPONENTS
12	BILL OF MATERIALS & COMPONENTS

O.A. FRAME DIMENSION	D.L.O. DIMENSION	GLASS TYPE	DESIGN PRESSURE (PSF)	
			POSITIVE	NEGATIVE
193.50" x 95.75"	42.50" x 88.63"	G1	115.0	135.0
193.50" x 95.75"	42.50" x 88.63"	G2	115.0	135.0

Documents Prepared By:

**RW** BUILDING CONSULTANTS, INC.  
P.O. Box 230 Valrico FL 33595  
Phone No.: 813.659.9197  
Florida Board of Professional Engineers  
Certificate Of Authorization No. 9813  
*RW* 8/27/12  
Lyndon F. Schmidt, P.E. No. 43409

PRODUCT: SLIDING GLASS DOOR

PART OR ASSEMBLY:  
TYPICAL ELEVATION, DESIGN PRESSURES & GENERAL NOTES

NO.	DATE	BY	REVISIONS

DATE: 8/24/12  
SCALE: N.T.S.  
DWG. BY: JK  
CHK. BY: LFS  
DRAWING NO.: FL-15903.15  
SHEET 1 OF 12

R:\A - Projects\Project Folders\Proj 1601 - 1700\PF 1692\D. RWBC Drawings\FL-15903.13-21.dwg, 2.15

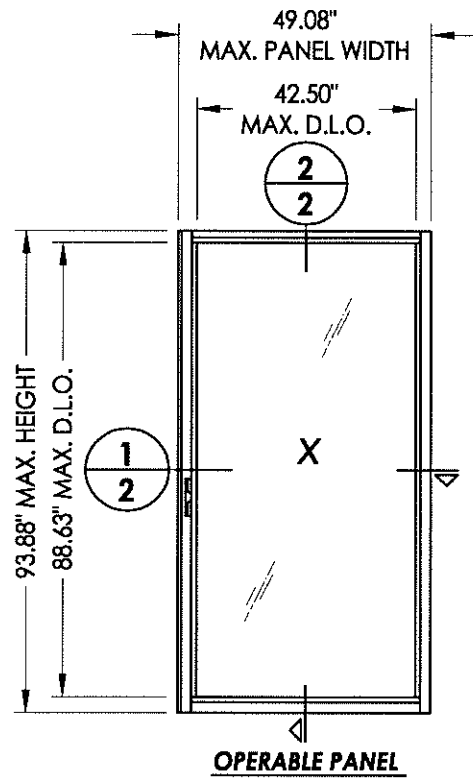

**OPERABLE PANEL**

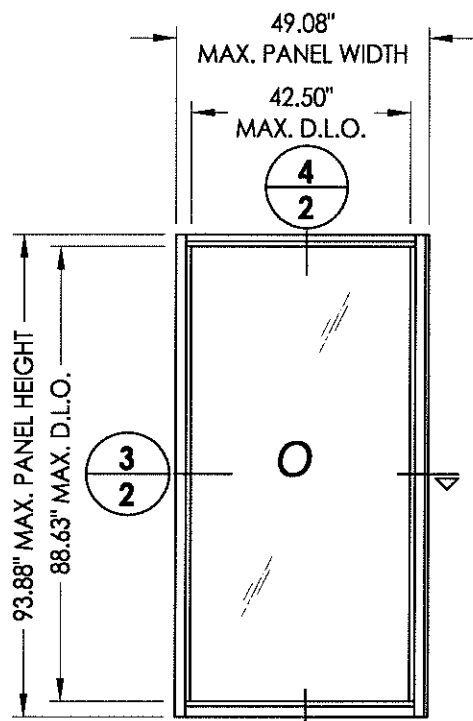

**FIXED PANEL**

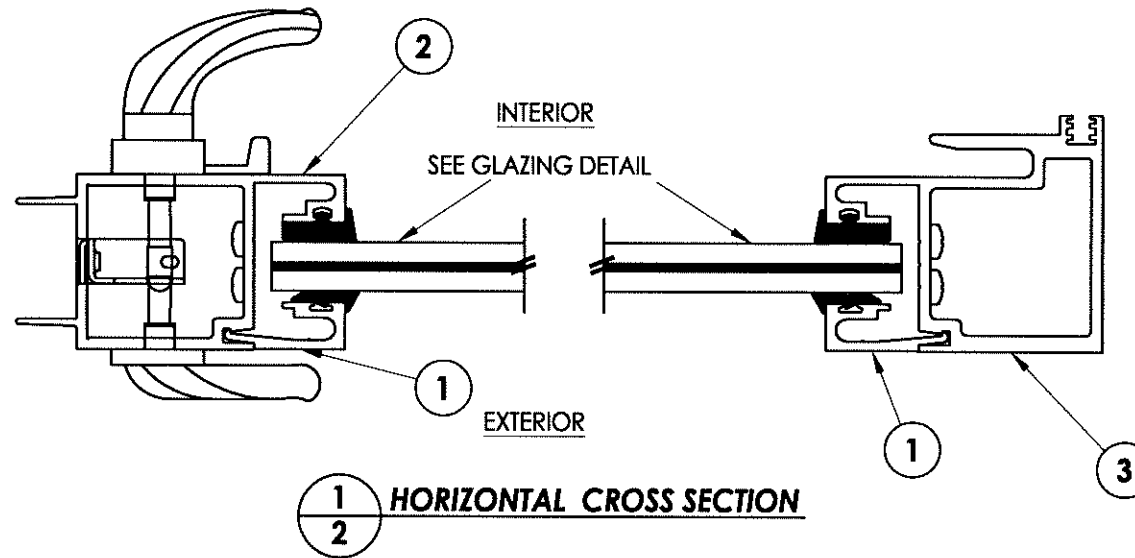

**1/2 HORIZONTAL CROSS SECTION**

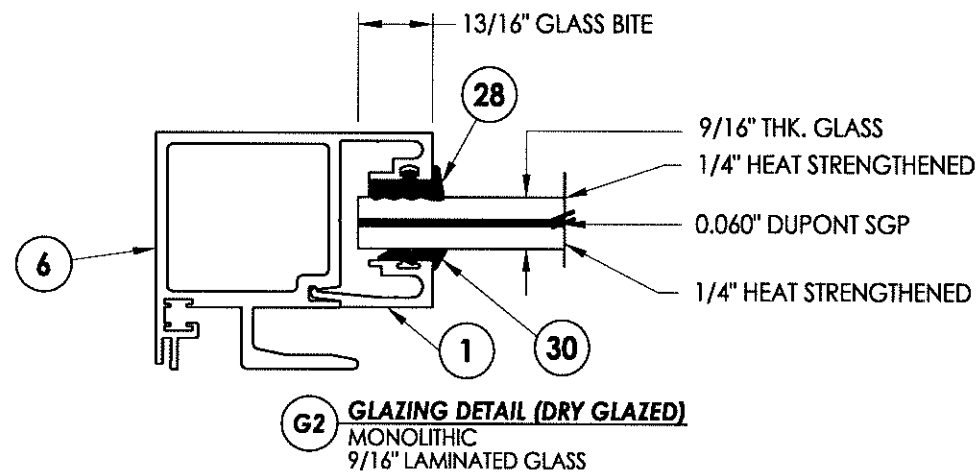

**G2 GLAZING DETAIL (DRY GLAZED)**  
MONOLITHIC  
9/16\"/>

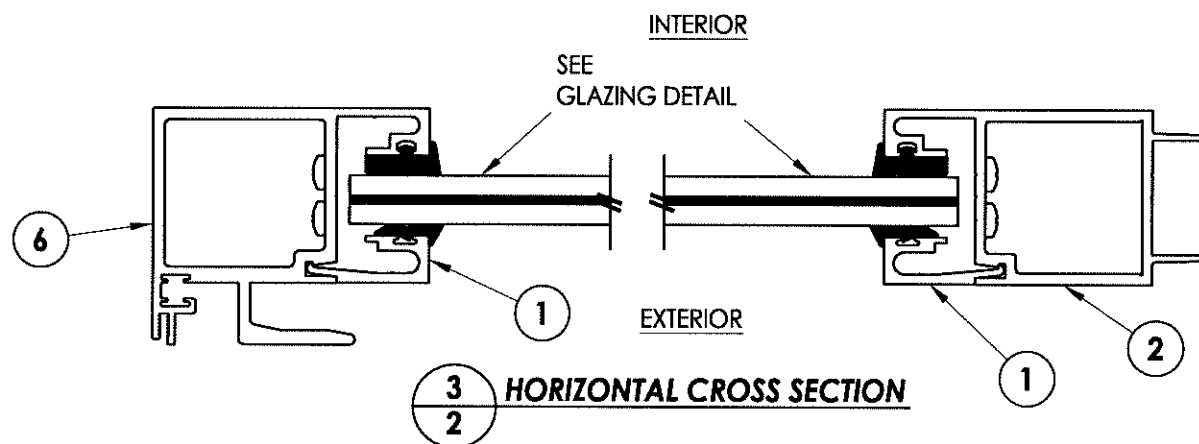

**3/2 HORIZONTAL CROSS SECTION**

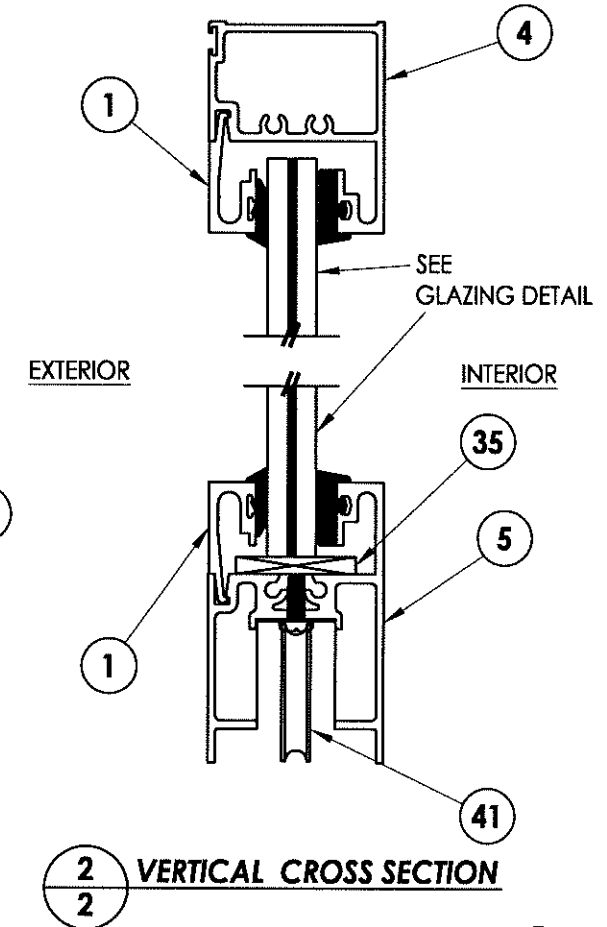

**2/2 VERTICAL CROSS SECTION**

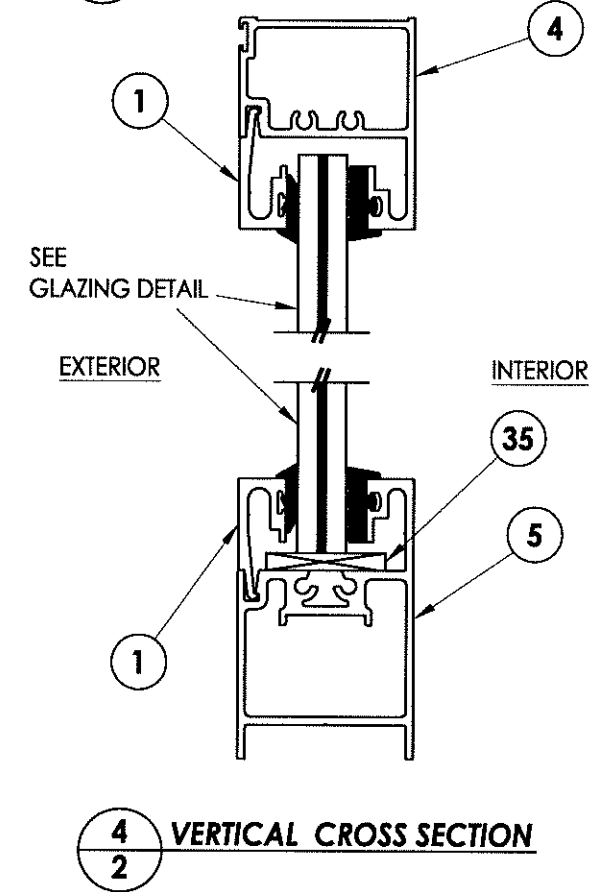

**4/2 VERTICAL CROSS SECTION**

Documents Prepared By:  
**RW** BUILDING CONSULTANTS, INC.  
P.O. Box 230 Valrico FL 33595  
Phone No.: 813.659.9197  
Florida Board of Professional Engineers  
Certificate Of Authorization No. 9813  
Lyndon F. Schmidt, P.E. No. 43409

PRODUCT: SLIDING GLASS DOOR  
PART OR ASSEMBLY: DOOR PANEL SECTIONS

NO.	DATE	BY

DATE: 8/24/12  
SCALE: N.T.S.  
DWG. BY: JK  
CHK. BY: LFS  
DRAWING NO.: FL-15903.15  
SHEET 2 OF 12

R:\A - Projects\Project Folders\Proj 1601 - 1700\PF 1692\DWG Drawings\FL-15903.13-21.dwg, 3.15

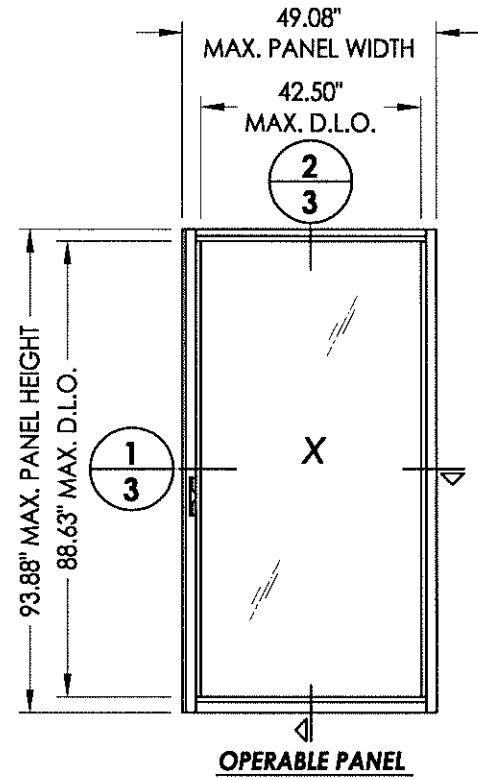

**OPERABLE PANEL**

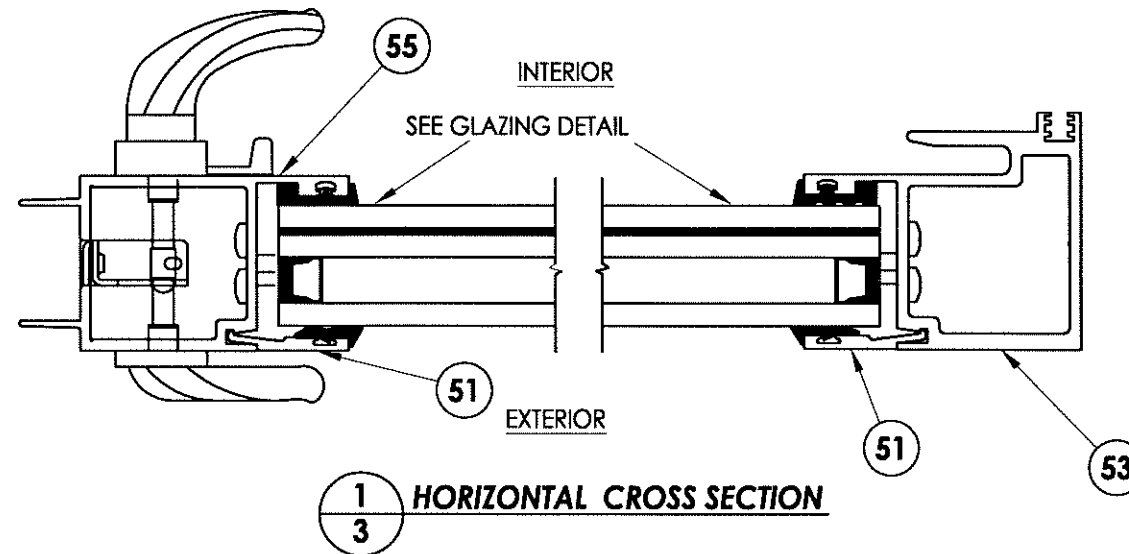

**1 HORIZONTAL CROSS SECTION**

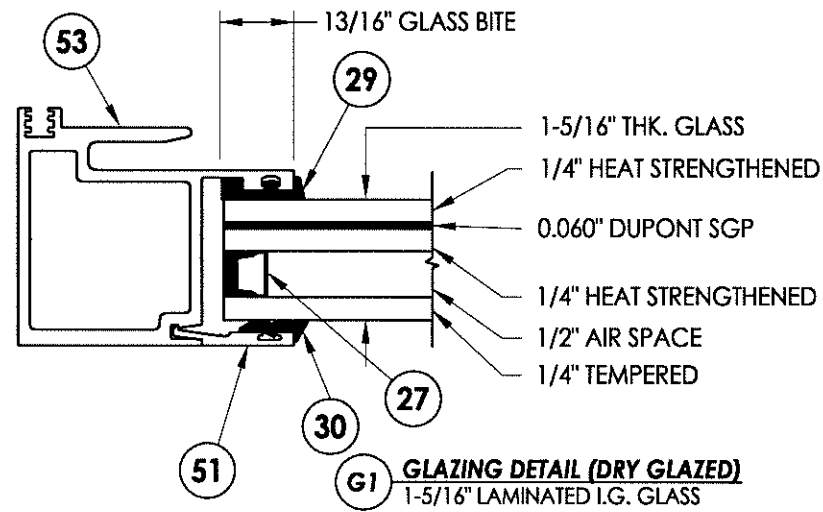

**GLAZING DETAIL (DRY GLAZED)**  
1-5/16" LAMINATED I.G. GLASS

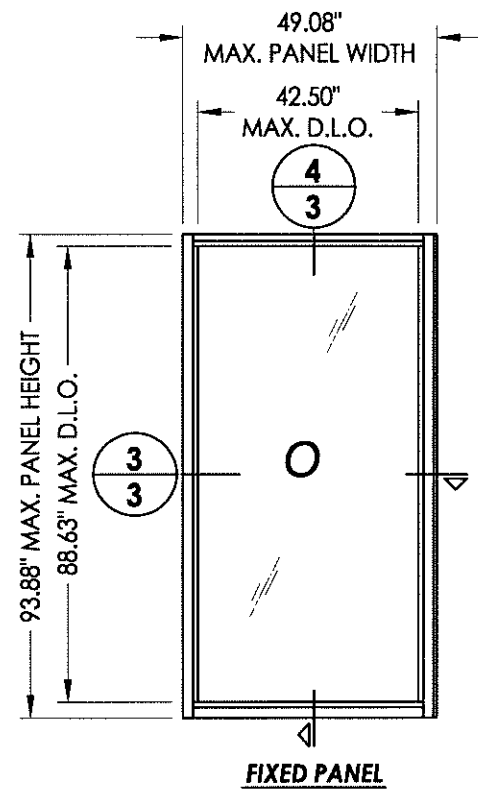

**FIXED PANEL**

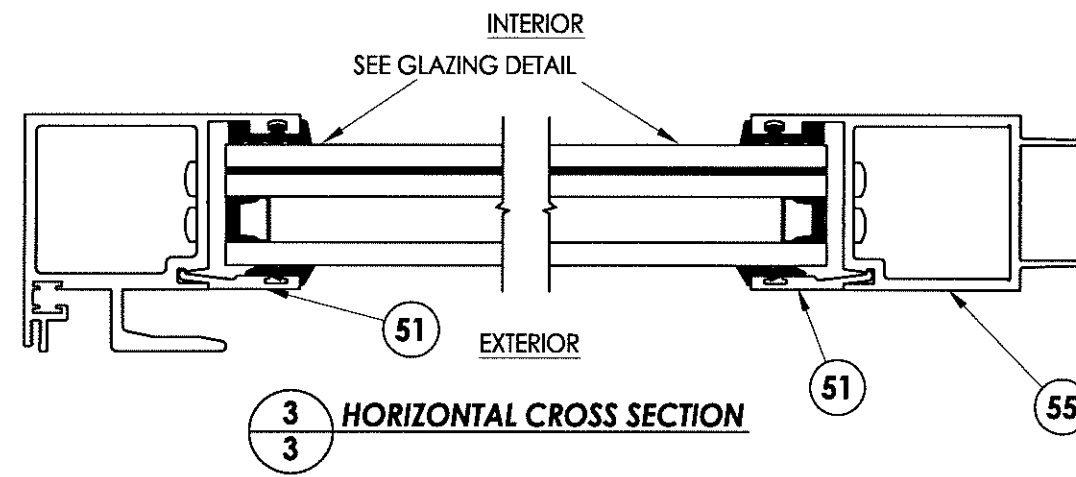

**3 HORIZONTAL CROSS SECTION**

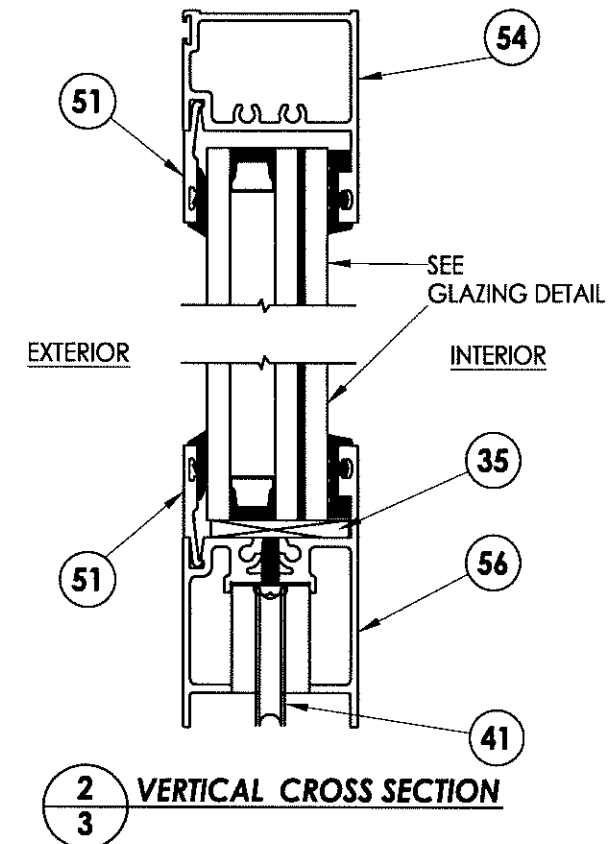

**2 VERTICAL CROSS SECTION**

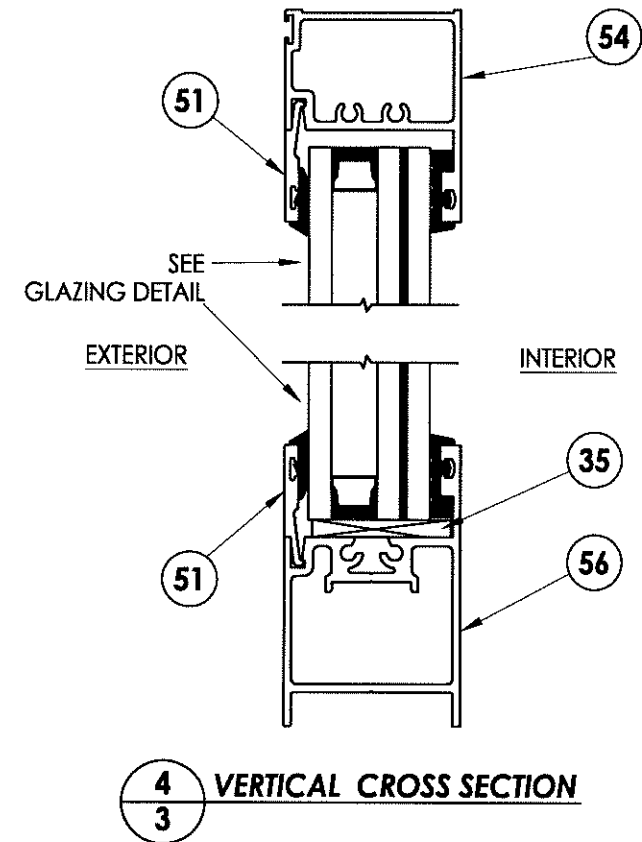

**4 VERTICAL CROSS SECTION**

Documents Prepared By:		R.W. BUILDING CONSULTANTS, INC. P.O. Box 230 Vairico FL 33595 Phone No.: 813.659.9197 Florida Board of Professional Engineers Certificate Of Authorization No. 9813 <i>Lyndon F. Schmidt</i> Lyndon F. Schmidt, P.E. No. 43409	
PRODUCT:	SLIDING GLASS DOOR		
PART OR ASSEMBLY:	DOOR PANEL SECTIONS		
		NO.	DATE
		BY	
		REVISIONS	
DATE: 8/24/12			
SCALE: N.T.S.			
DWG. BY: JK			
CHK. BY: LFS			
DRAWING NO.: FL-15903.15			
SHEET 3 OF 12			

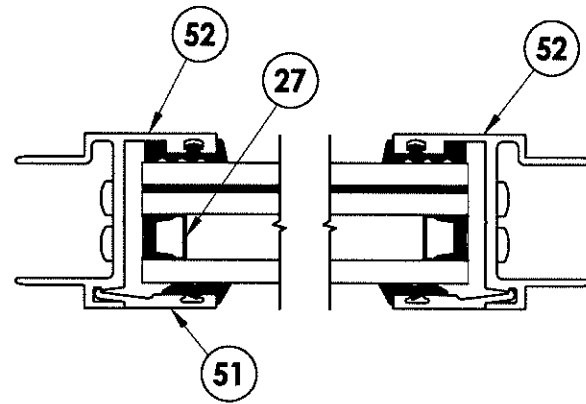
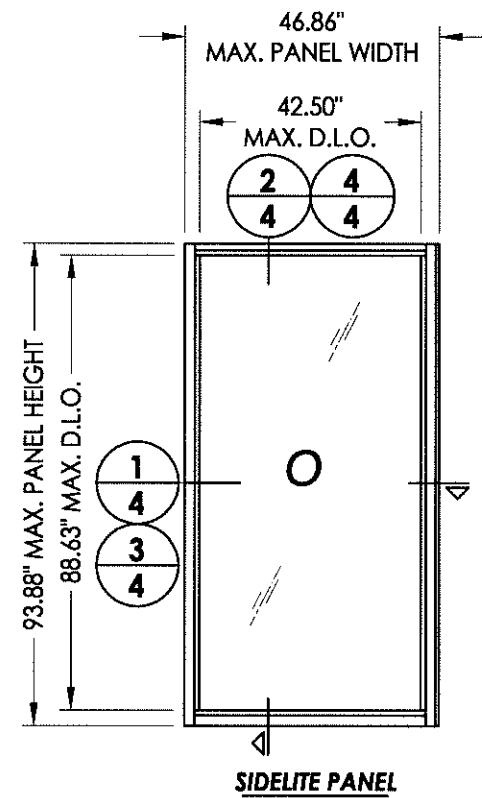

1/4 **HORIZONTAL CROSS SECTION**

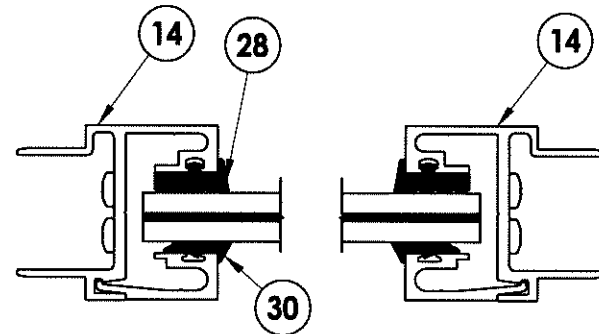

3/4 **HORIZONTAL CROSS SECTION**

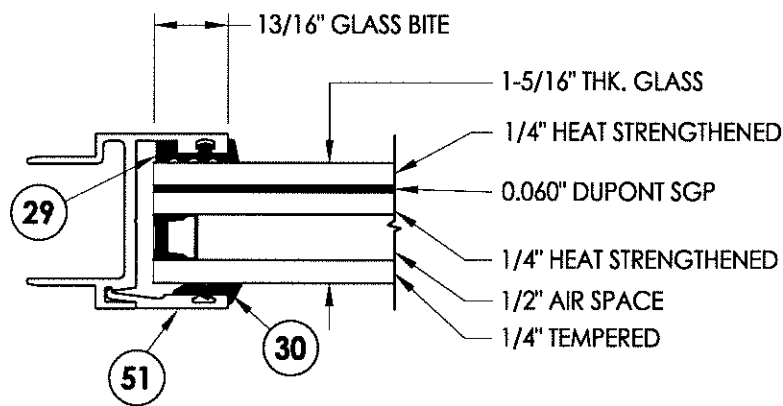

G1 **GLAZING DETAIL**  
1-5/16" LAMINATED I.G. GLASS

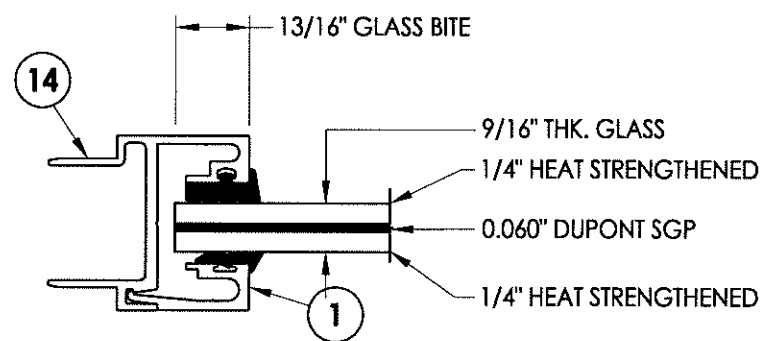

G2 **GLAZING DETAIL**  
MONOLITHIC  
9/16" LAMINATED GLASS

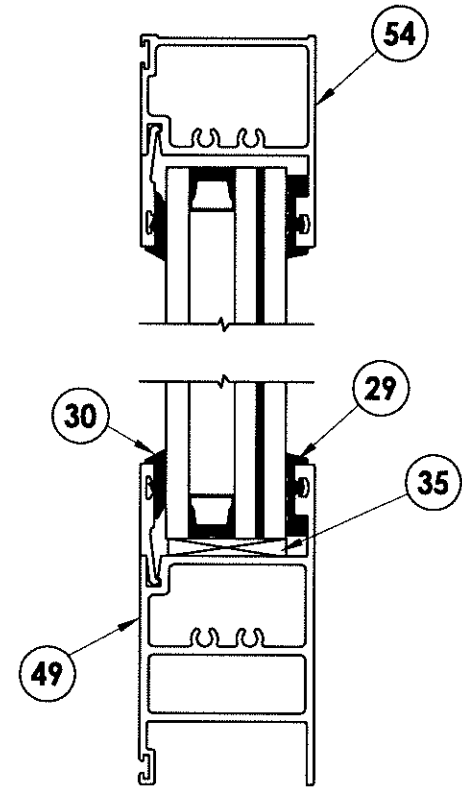

2/4 **VERTICAL CROSS SECTION**

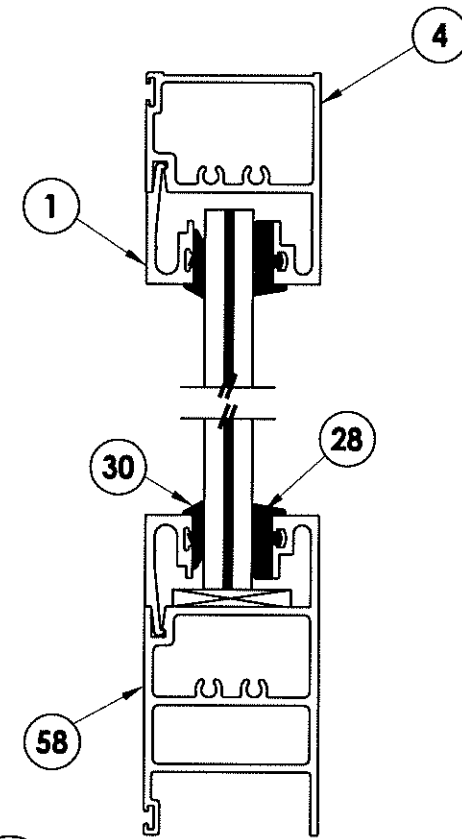

4/4 **VERTICAL CROSS SECTION**

Documents Prepared By:

**RW** BUILDING CONSULTANTS, INC.  
P.O. Box 230 Valrico FL, 33595  
Phone No.: 813.659.9197  
Florida Board of Professional Engineers  
Certificate Of Authorization No. 9813  
*LFS* P. 27.12  
Lyndell F. Schmidt, P.E. No. 43409

PRODUCT: SLIDING GLASS DOOR

PART OR ASSEMBLY: SIDELITE PANEL SECTIONS

NO.	DATE	BY

DATE: 8/24/12  
SCALE: N.T.S.  
DWG. BY: JK  
CHK. BY: LFS  
DRAWING NO.: FL-15903.15  
SHEET 4 OF 12

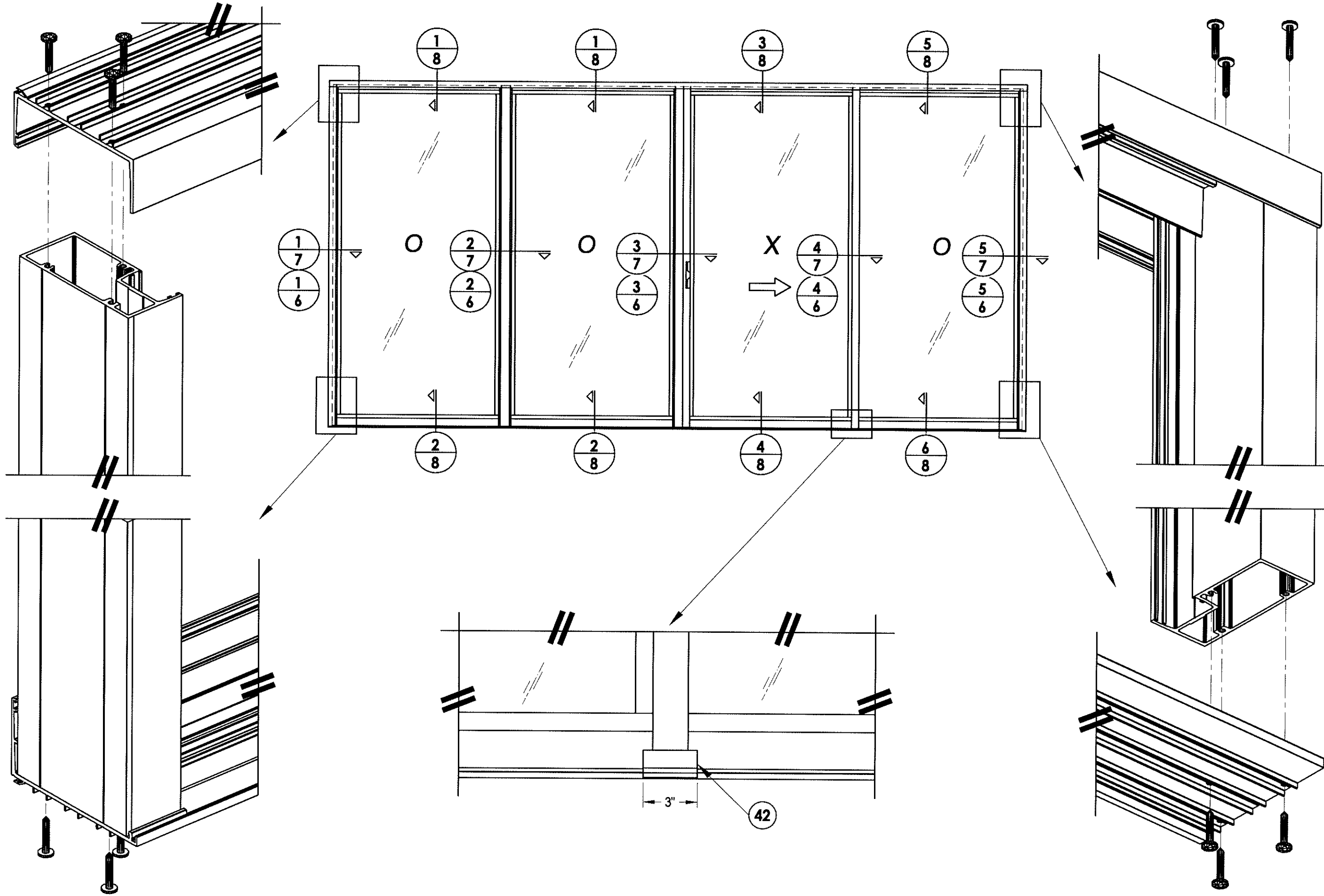

DATE: 8/24/12  
 SCALE: N.T.S.  
 DWG. BY: JK  
 CHK. BY: LFS  
 DRAWING NO.: FL-15903.15  
 SHEET 5 of 12

NO.	DATE	BY

PRODUCT: SLIDING GLASS DOOR  
 PART OR ASSEMBLY: CORNER DETAIL

Documents Prepared By:  
 RW BUILDING CONSULTANTS, INC.  
 P.O. Box 230 Vairico FL 33595  
 Phone No.: 813.659.9197  
 Florida Board of Professional Engineers  
 Certificate Of Authorization No. 9813  
 Lyndon F. Schmidt, P.E. No. 43409

R:\A - Projects\Project Folders\Proj 1601 - 1700\PF 1692\D. RWBC Drawings\FL-15903.13-21.dwg, 6..15

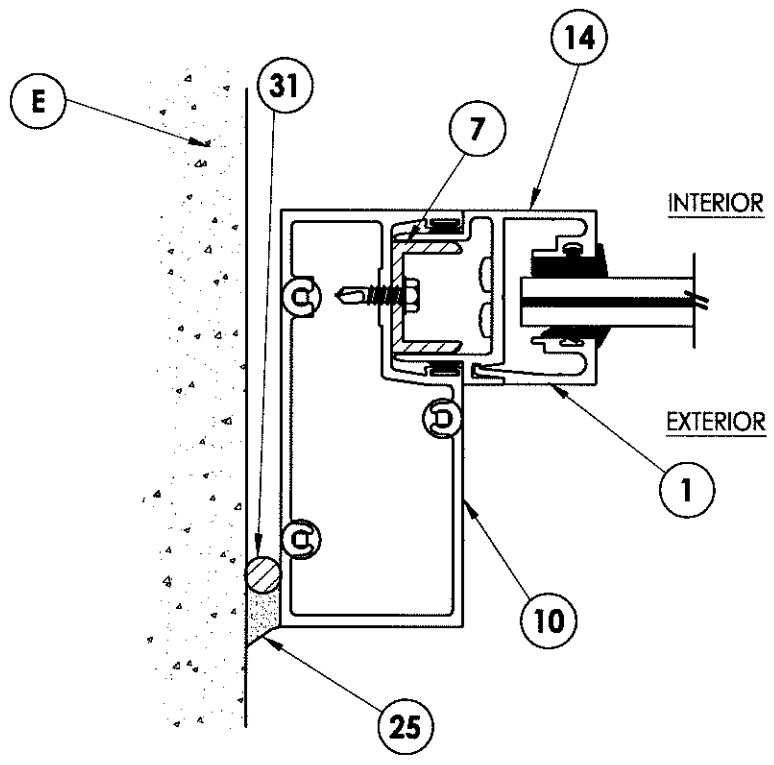

1  
6 HORIZONTAL CROSS SECTION

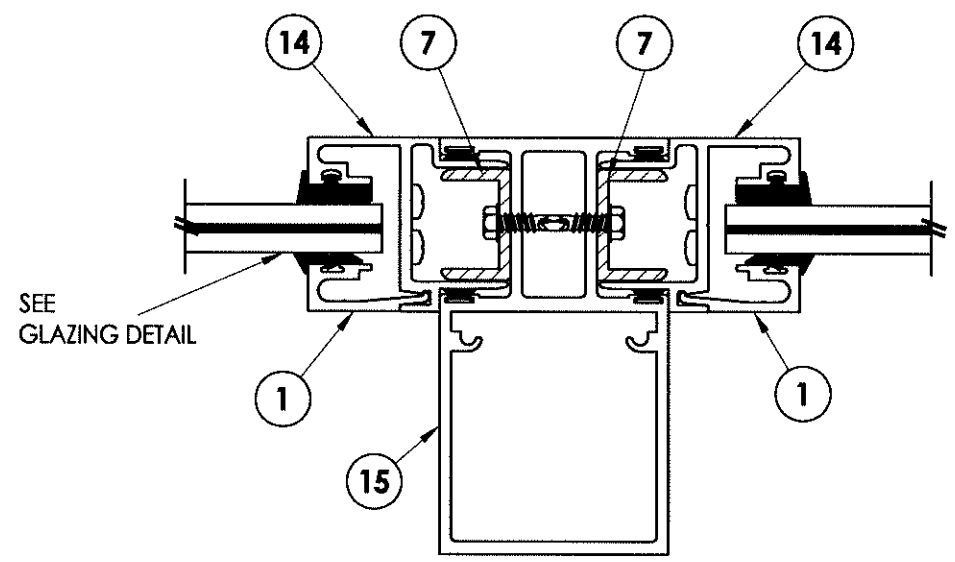

2  
6 HORIZONTAL CROSS SECTION

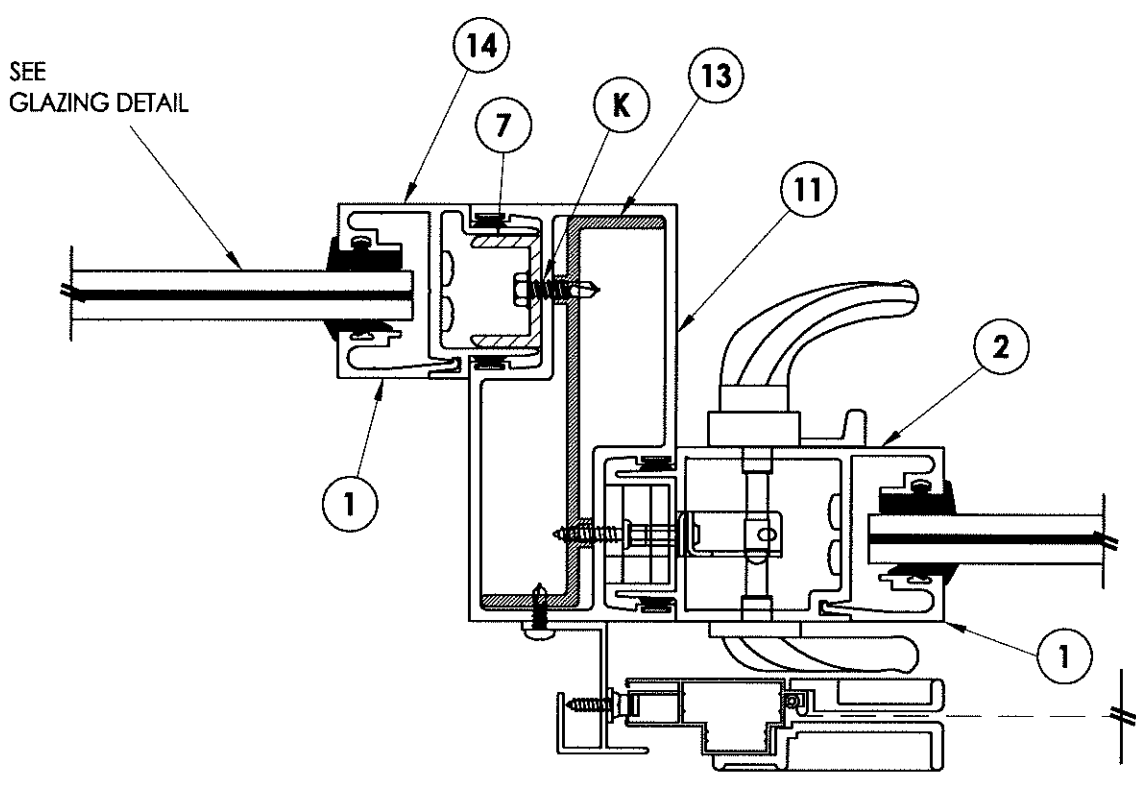

3  
6 HORIZONTAL CROSS SECTION

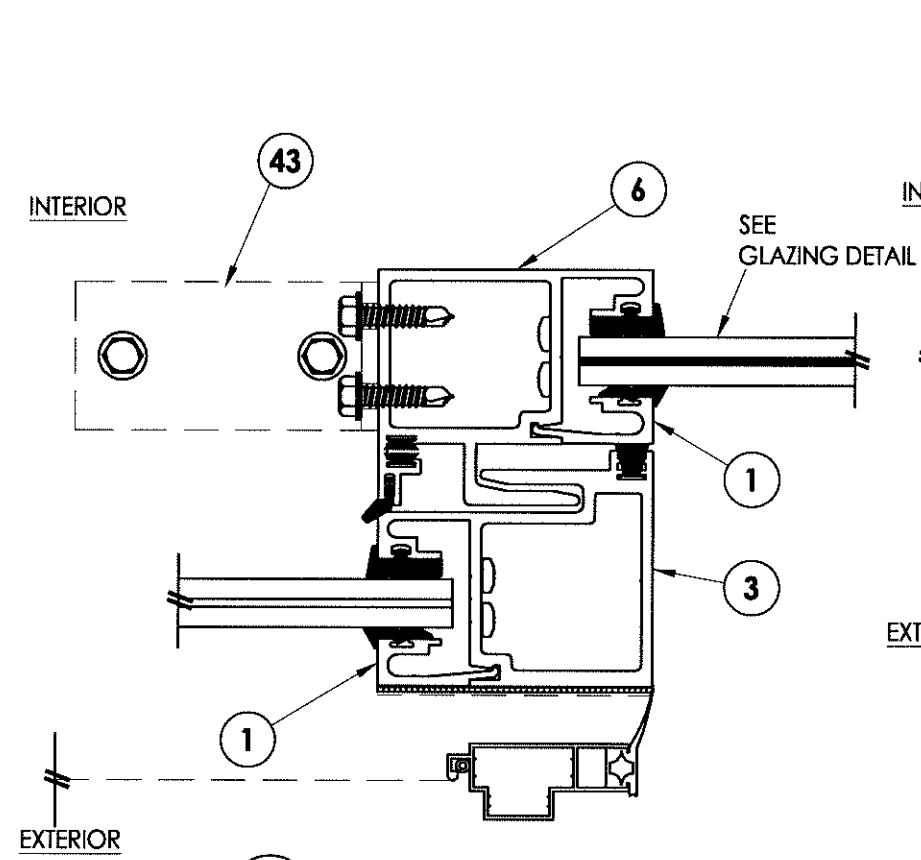

4  
6 HORIZONTAL CROSS SECTION

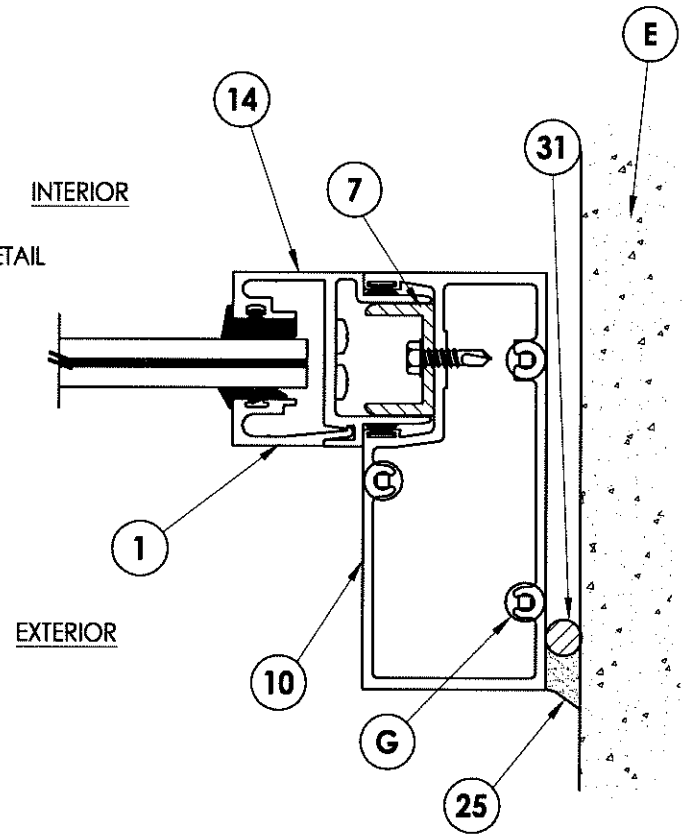

5  
6 HORIZONTAL CROSS SECTION

PRODUCT:		SLIDING GLASS DOOR	
PART OR ASSEMBLY:		HORIZONTAL CROSS SECTION	
NO.	DATE	BY	REVISIONS
DATE: 8/24/12			
SCALE: N.T.S.			
DWG. BY: JK			
CHK. BY: LFS			
DRAWING NO.: FL-15903.15			
SHEET 6 OF 12			

Documents Prepared By:  
**RW** BUILDING CONSULTANTS, INC.  
 P.O. Box 230 Valrico FL 33595  
 Phone No.: 813.659.9197  
 Florida Board of Professional Engineers  
 Certificate Of Authorization No. 9813  
*LFS*  
 Lynden F. Schmidt, P.E. No. 43409

© 2012 R.W. BUILDING CONSULTANTS INC.

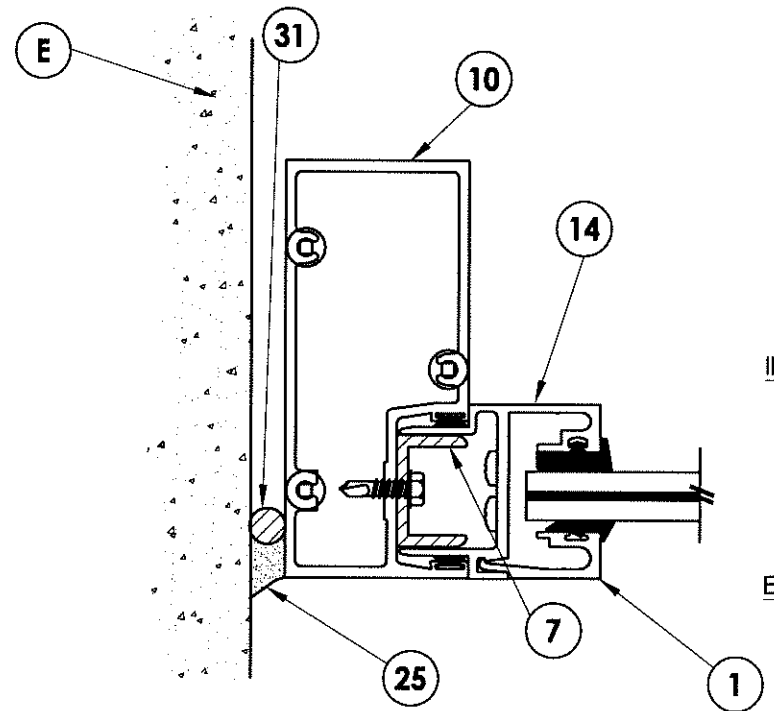

**1**  
**7** HORIZONTAL CROSS SECTION

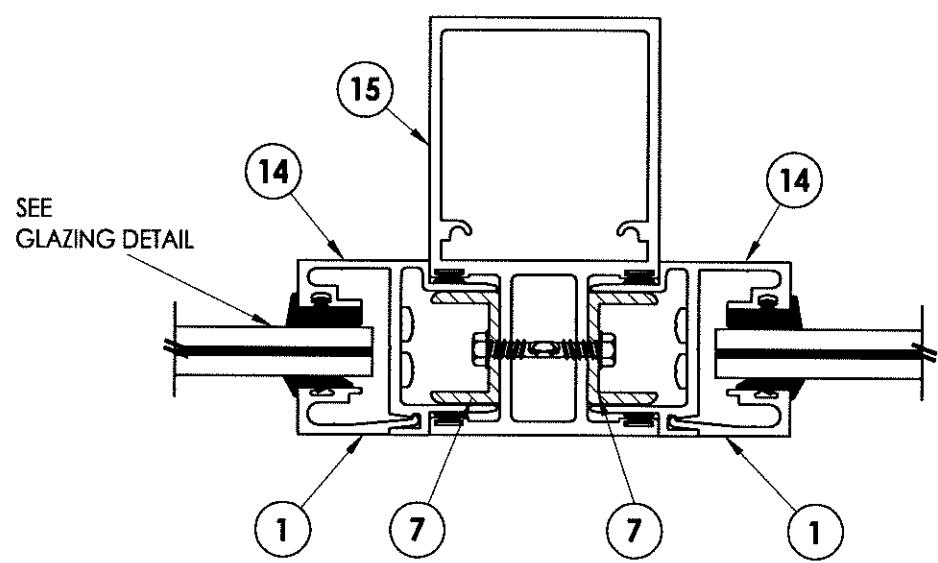

**2**  
**7** HORIZONTAL CROSS SECTION

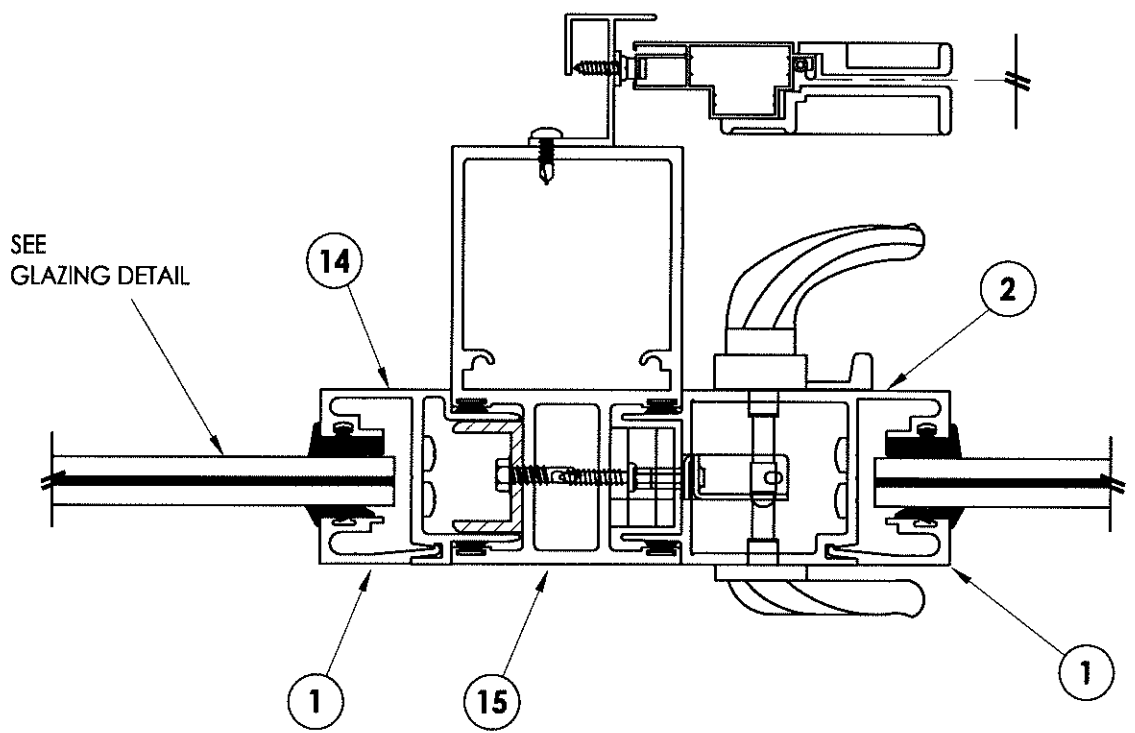

**3**  
**7** HORIZONTAL CROSS SECTION

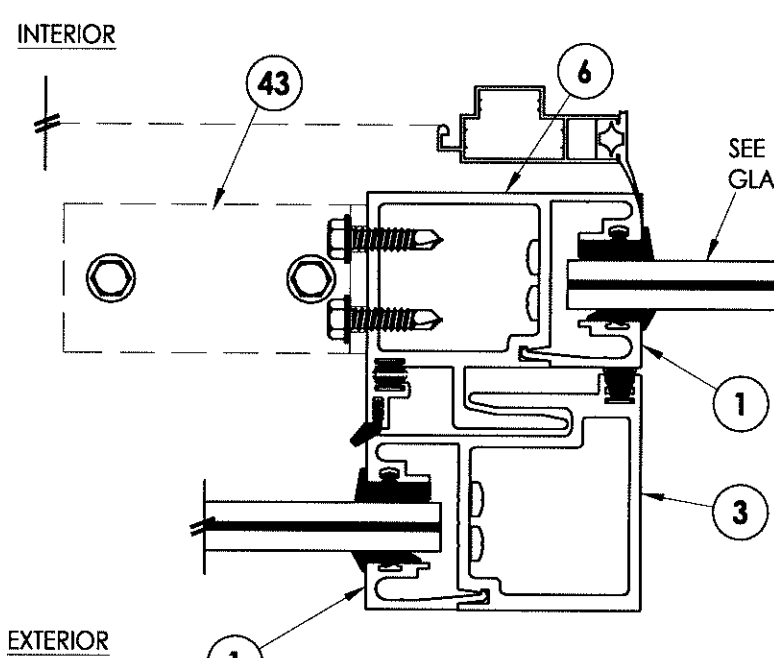

**4**  
**7** HORIZONTAL CROSS SECTION

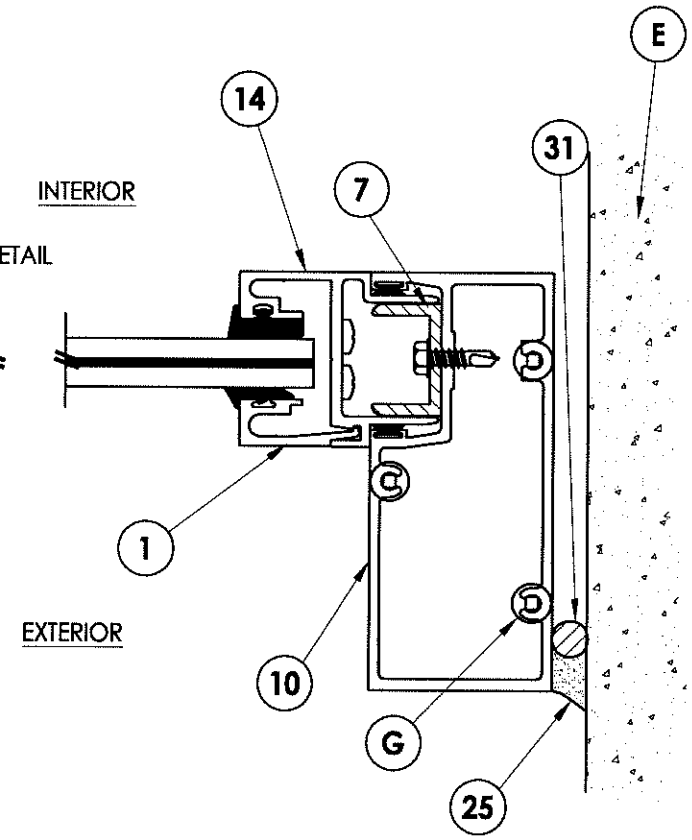

**5**  
**7** HORIZONTAL CROSS SECTION

Documents Prepared By:		BUILDING CONSULTANTS, INC. P.O. Box 230 Valrico FL 33595 Phone No.: 813.659.9197 Florida Board of Professional Engineers Certificate Of Authorization No. 9813 <i>RW</i> 8.27.12 Lyndon F. Schmidt, P.E. No. 43409	
PRODUCT:	SLIDING GLASS DOOR	NO.	DATE
PART OR ASSEMBLY:	HORIZONTAL CROSS SECTION	BY	
		REVISIONS	
		NO.	DATE
		BY	
DATE: 8/24/12			
SCALE: N.T.S.			
DWG. BY: JK			
CHK. BY: LFS			
DRAWING NO.: FL-15903.15			
SHEET 7 OF 12			

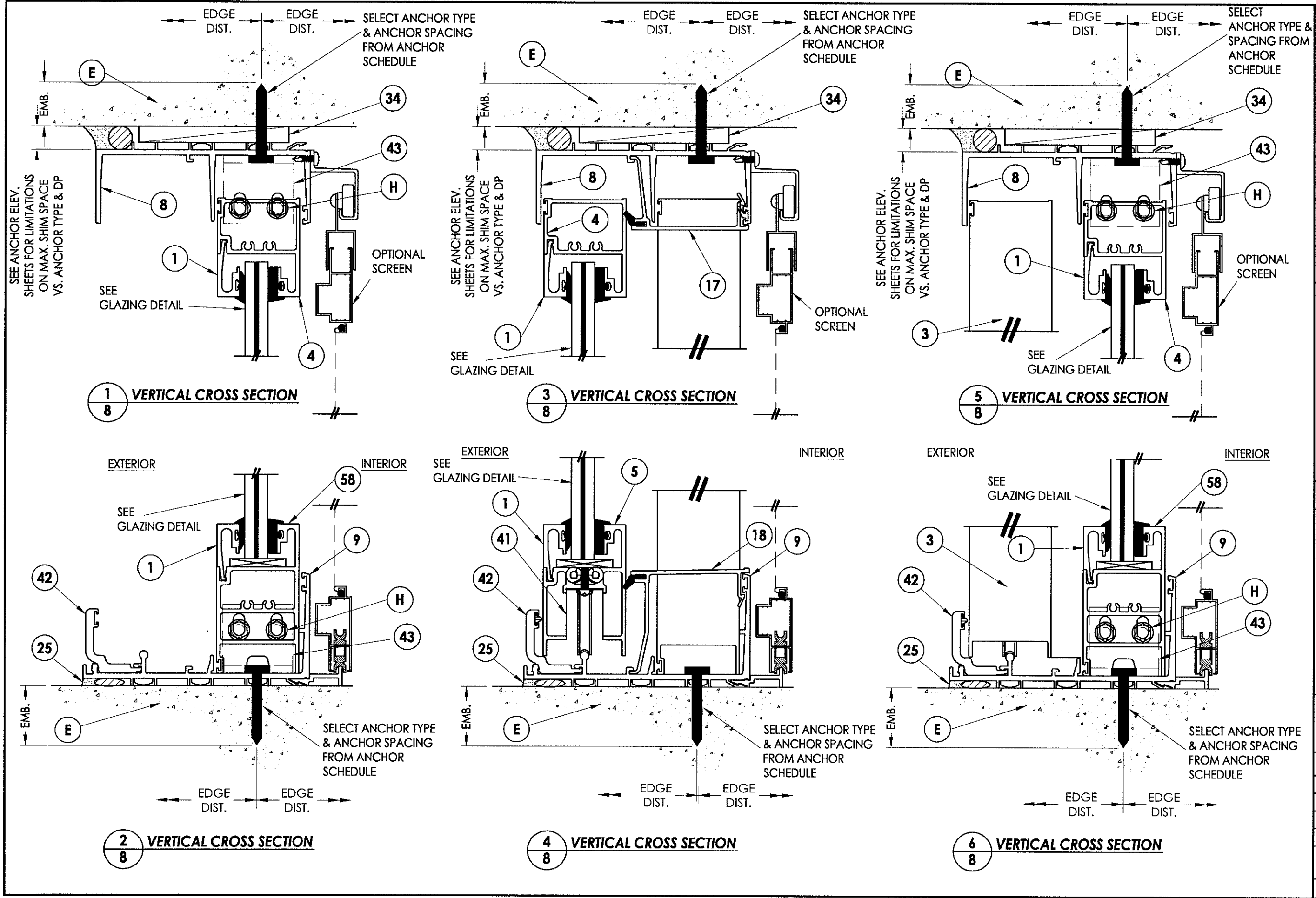

Documents Prepared By:  
**RW** BUILDING CONSULTANTS, INC.  
 P.O. Box 230 Valrico FL 33595  
 Phone No.: 813.659.9197  
 Florida Board of Professional Engineers  
 Certificate Of Authorization No. 9813  
 Lyndon F. Schmitt, P.E. No. 43409

PRODUCT: SLIDING GLASS DOOR  
 PART OR ASSEMBLY:  
 VERTICAL CROSS SECTION

NO.	DATE	BY

REVISIONS

DATE: 8/24/12  
 SCALE: N.T.S.  
 DWG. BY: JK  
 CHK. BY: LFS  
 DRAWING NO.: FL-15903.15  
 SHEET 8 OF 12

© 2012 R.W. BUILDING CONSULTANTS INC.



R:\A - Projects\Project Folders\Proj 1601 - 1700\PF 1692\D. RWBC Drawings\FL-15903.13-21.dwg, 9.15

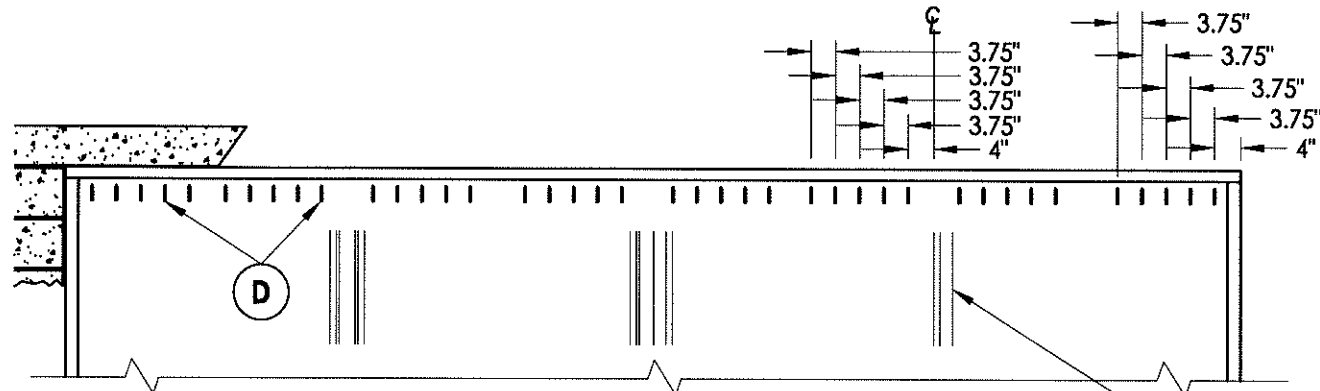

**FRAME ANCHORING @ HEAD**  
 DP <= 80 PSF  
 Max. shim space <= .625"

MEETING STILES  
 SHOWN FOR  
 LOCATION  
 REFERENCE ONLY

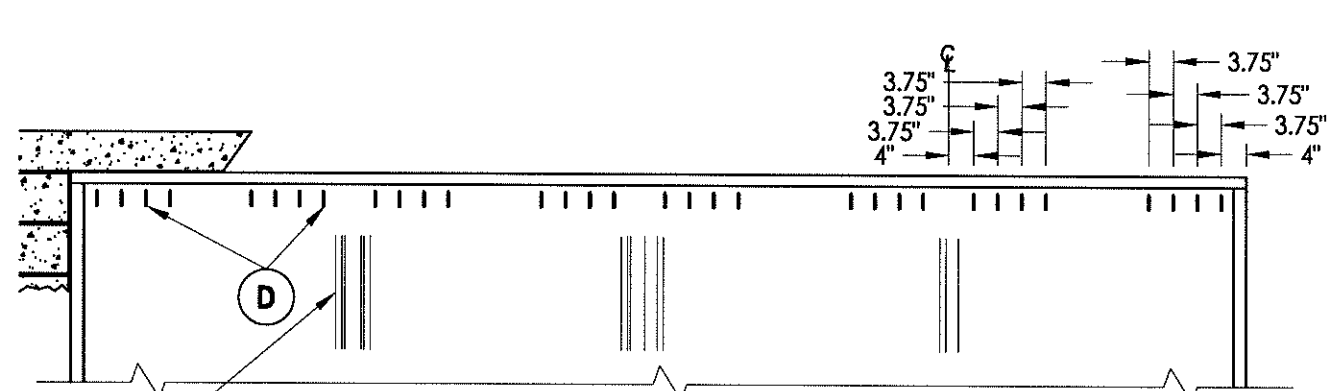

**FRAME ANCHORING @ HEAD**  
 DP <= 135 PSF  
 Max. shim space <= .25"

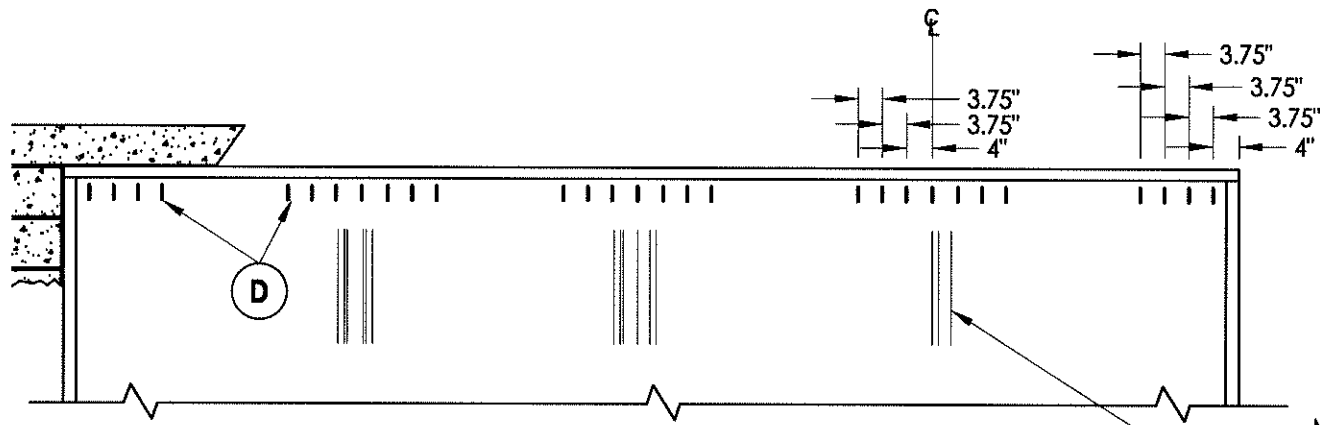

**FRAME ANCHORING @ HEAD**  
 DP <= 80 PSF  
 Max. shim space <= .41"

MEETING STILES  
 SHOWN FOR  
 LOCATION  
 REFERENCE ONLY

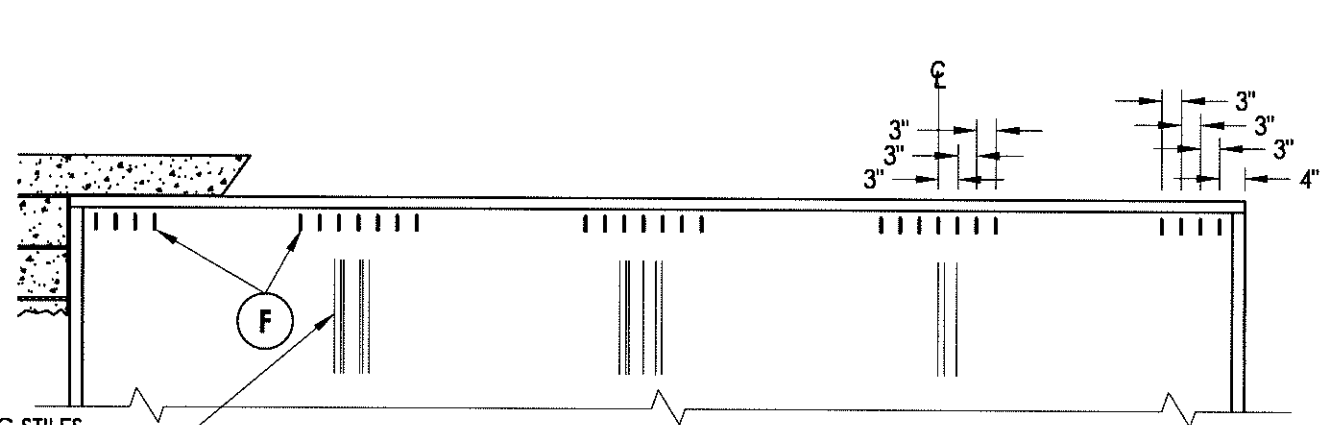

**FRAME ANCHORING @ HEAD**  
 DP <= 135 PSF  
 Max. shim space <= .625"

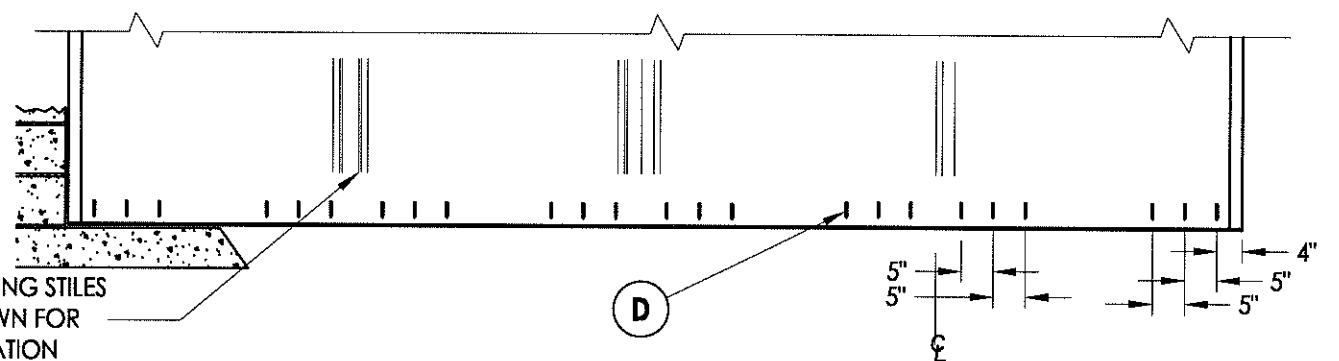

MEETING STILES  
 SHOWN FOR  
 LOCATION  
 REFERENCE ONLY

**FRAME ANCHORING @ SILL**  
 DP <= 135 PSF  
 Max. shim space <= 0.17"

SUBSTRATE	ANCHOR SCHEDULE	
CONCRETE	(D)	5/16" x 2-3/4" ITW (XL) HWH concrete screw with 1.75" Min. embedment, 4" minimum edge distance and 3.75" minimum clearance to adjacent concrete anchors. Concrete is 2,899 PSI minimum conforming to ACI 301.
	(F)	3/8" diameter x 2-1/4" ITW Dyna-Bolt sleeve anchor with 1.5" minimum embedment, 2.5" minimum edge distance and 3.0" minimum clearance to adjacent concrete screws. Concrete is 2,000 PSI minimum conforming to ACI 301.

Documents Prepared By:  
**RW** BUILDING CONSULTANTS, INC.  
 P.O. Box 230 Valrico FL 33595  
 Phone No.: 813.659.9197  
 Florida Board of Professional Engineers  
 Certificate of Authorization No. 9813  
 Lyndon F. Schmidt, P.E. No. 43409

PRODUCT: SLIDING GLASS DOOR  
 PART OR ASSEMBLY: ANCHORING  
 CONCRETE SUBSTRATE

NO.	DATE	BY	REVISIONS

DATE: 8/24/12  
 SCALE: N.T.S.  
 DWG. BY: JK  
 CHK. BY: LFS  
 DRAWING NO.: FL-15903.15  
 SHEET 9 OF 12

SUBSTRATE		ANCHOR SCHEDULE
CONCRETE	(D)	5/16" x 2-3/4" ITW (XL) HWH concrete screw with 1.75" Min. embedment, 4" minimum edge distance and 3.75" minimum clearance to adjacent concrete anchors. Concrete is 2,899 PSI minimum conforming to ACI 301.
STEEL	(H)	1/4"-20 HWH Hilti KWIK PRO self-drilling screws. Steel with 0.125" minimum wall thickness conforming to ASTM A500 Grade B, Fy = 46,000 PSI & Fu = 58,000 PSI or ASTM A653, Fy = 33,000 PSI, Fu = 45,000 PSI. Minimum embedment of 3 threads through steel substrate.

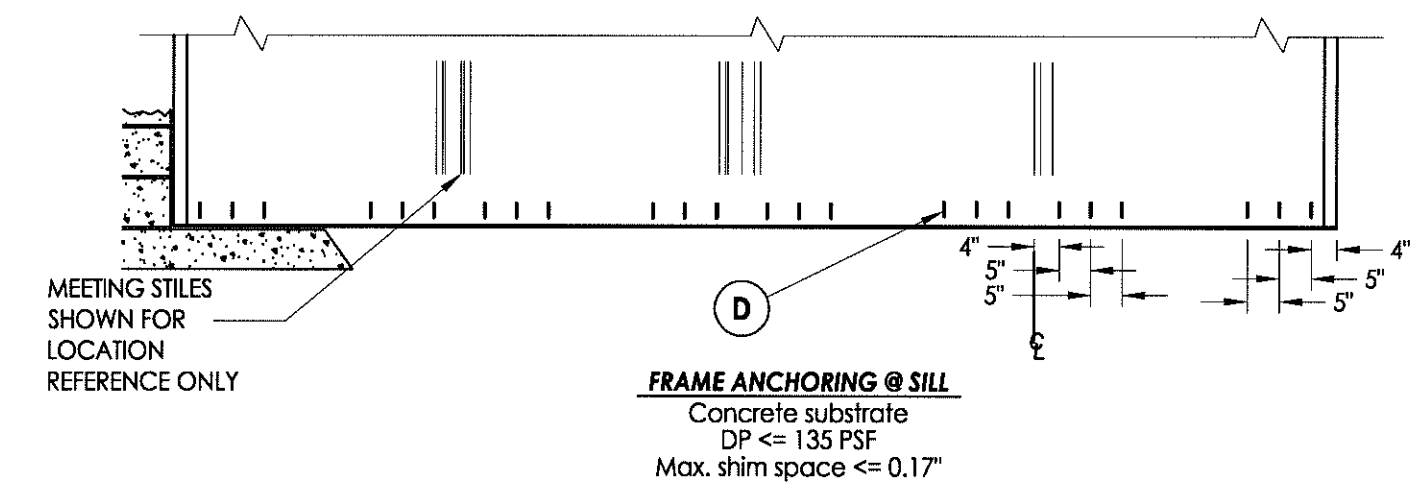
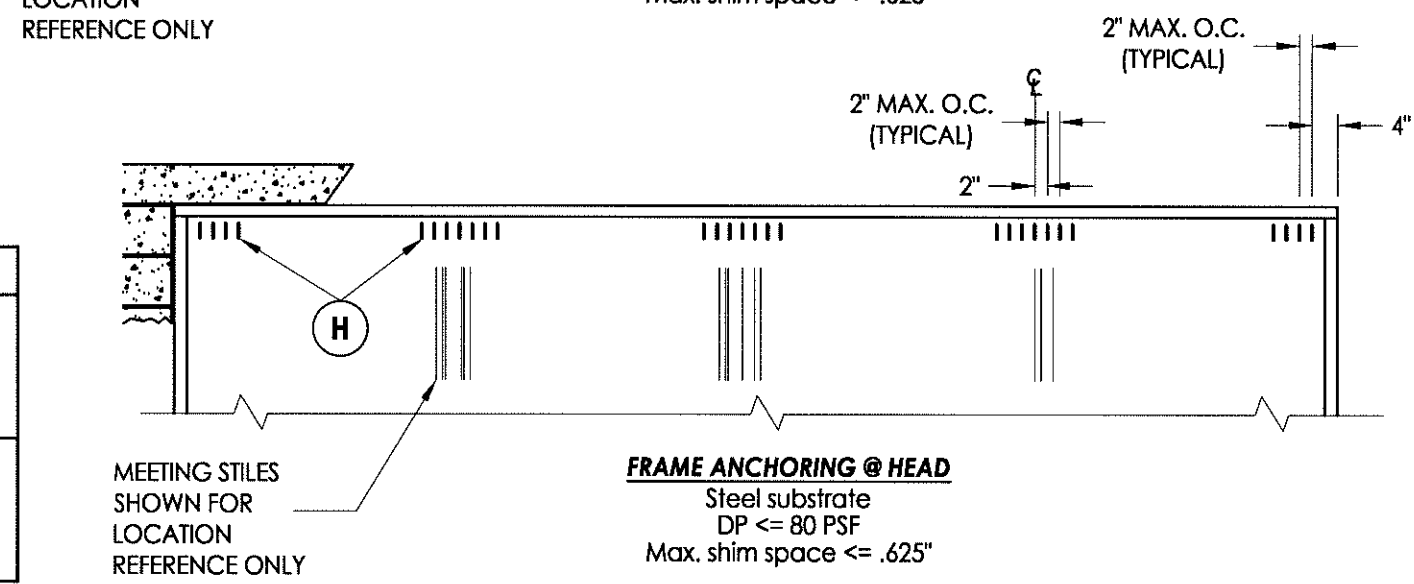
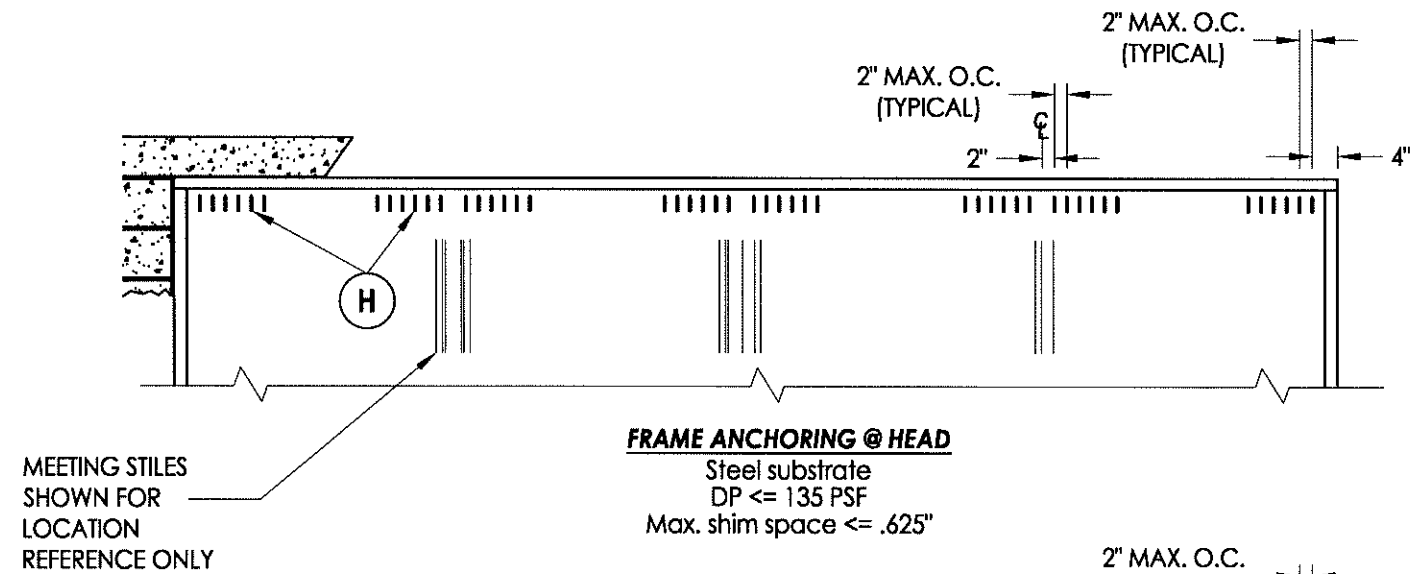

Documents Prepared By:  
**RW** BUILDING CONSULTANTS, INC.  
 P.O. Box 230 Valrico FL, 33595  
 Phone No.: 813.659.9197  
 Florida Board of Professional Engineers  
 Certificate Of Authorization No. 9813  
 Lyndon F. Schmidt, P.E. No. 43409  
 8.27.12

PRODUCT: SLIDING GLASS DOOR  
 PART OR ASSEMBLY: ANCHORING STEEL SUBSTRATE

NO.	DATE	BY	REVISIONS

DATE: 8/24/12  
 SCALE: N.T.S.  
 DWG. BY: JK  
 CHK. BY: LFS  
 DRAWING NO.: FL-15903.15  
 SHEET 10 OF 12

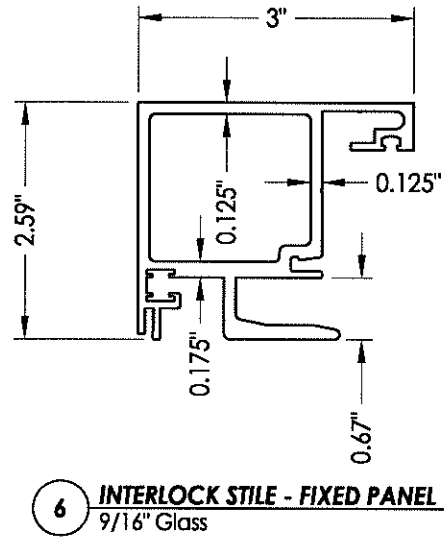

**6 INTERLOCK STILE - FIXED PANEL**  
9/16" Glass

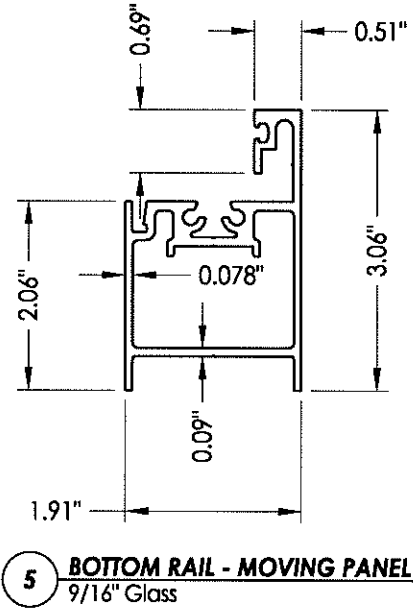

**5 BOTTOM RAIL - MOVING PANEL**  
9/16" Glass

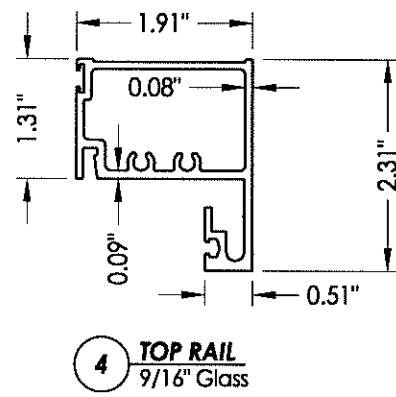

**4 TOP RAIL**  
9/16" Glass

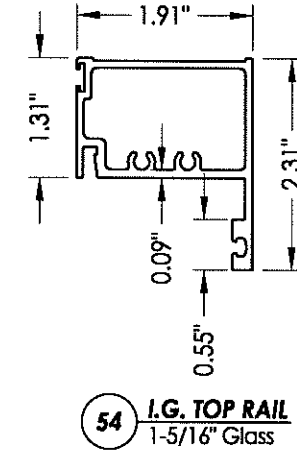

**54 I.G. TOP RAIL**  
1-5/16" Glass

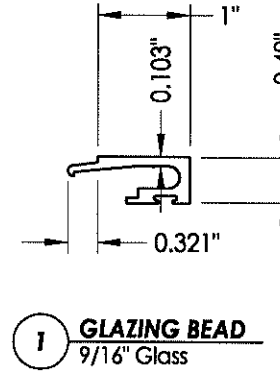

**1 GLAZING BEAD**  
9/16" Glass

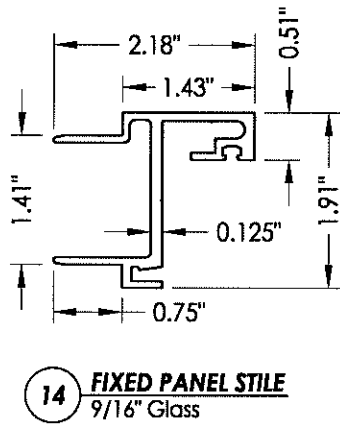

**14 FIXED PANEL STILE**  
9/16" Glass

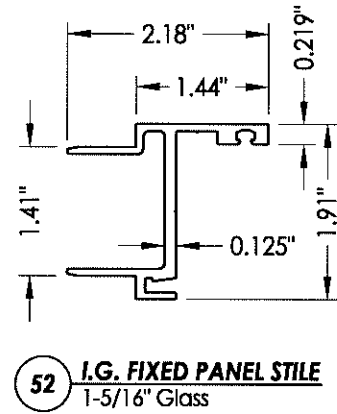

**52 I.G. FIXED PANEL STILE**  
1-5/16" Glass

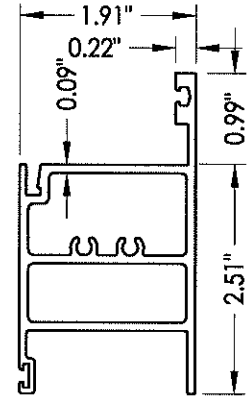

**49 I.G. BOTTOM RAIL - FIXED PANEL**  
1-5/16" GLASS

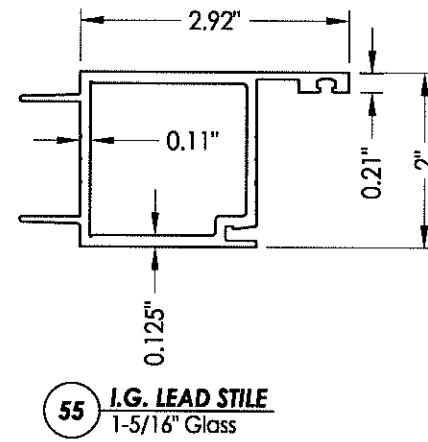

**55 I.G. LEAD STILE**  
1-5/16" Glass

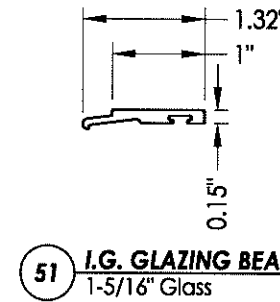

**51 I.G. GLAZING BEAD**  
1-5/16" Glass

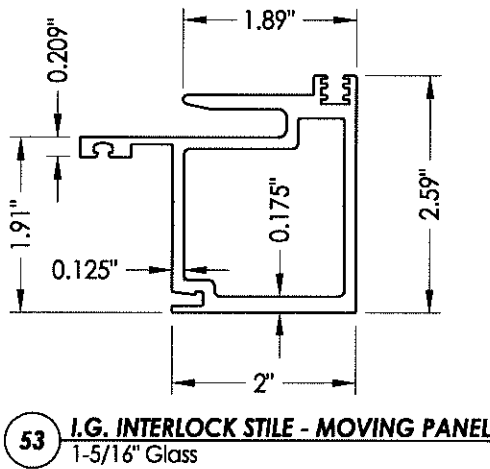

**53 I.G. INTERLOCK STILE - MOVING PANEL**  
1-5/16" Glass

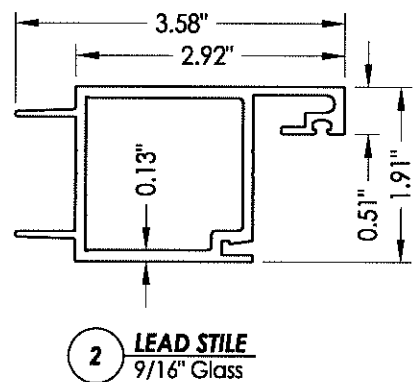

**2 LEAD STILE**  
9/16" Glass

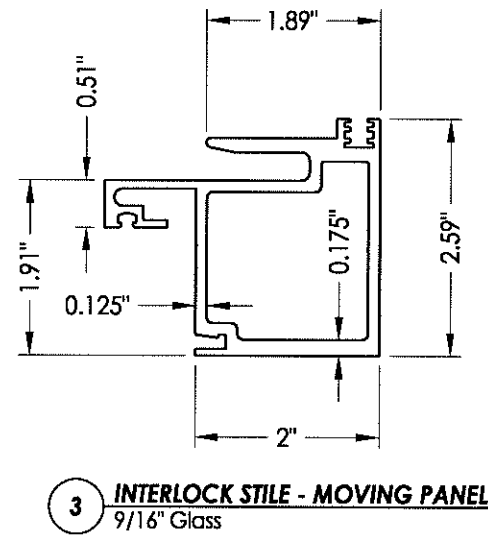

**3 INTERLOCK STILE - MOVING PANEL**  
9/16" Glass

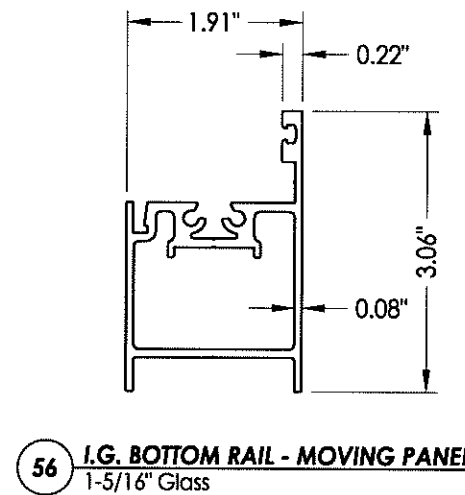

**56 I.G. BOTTOM RAIL - MOVING PANEL**  
1-5/16" Glass

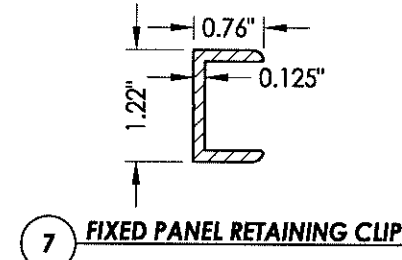

**7 FIXED PANEL RETAINING CLIP**

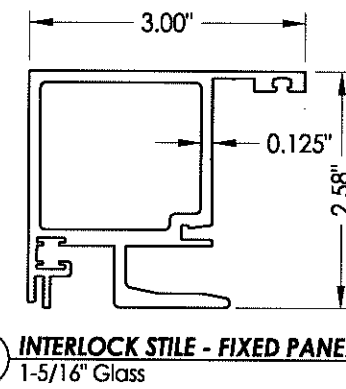

**57 INTERLOCK STILE - FIXED PANEL**  
1-5/16" Glass

PRODUCT:

SLIDING GLASS DOOR

PART OR ASSEMBLY:

COMPONENTS

NO.	DATE	BY

DATE: 02/26/08  
SCALE: N.T.S.  
DWG. BY: JK  
CHK. BY: LFS  
DRAWING NO.: FL-15903.15  
SHEET 11 OF 12

Documents Prepared By:

**RW** BUILDING CONSULTANTS, INC.  
P.O. Box 230 Valrico FL 33595  
Phone No.: 813.659.9197  
Florida Board of Professional Engineers  
Certificate of Authorization No. 9813  
Lyndon F. Schmidt, P.E. No. 43409

BILL OF MATERIALS		
ITEM	DESCRIPTION	MATERIAL
D	5/16" X 2-3/4" ITW HWH CONCRETE SCREW	STEEL
E	MASONRY - 3,192 PSI MIN. CONCRETE CONFORMING TO ACI 301 OR HOLLOW BLOCK CONFORMING TO ASTM C90	CONCRETE
F	3/8" X 2-1/2" DYNA BOLT SLEEVE ANCHOR (ZINC PLATED)	STEEL
G	#10 X 1-1/2" SQ-PH ASSEMBLY SCREW	STL. STEEL
H	1/4"-20 HWH HILTI KWIK PRO SELF-DRILLING SCREW (WITH KWIK-COTE COATING)	STEEL
K	#10 X 3/4" HH-SELF TAP ASSEMBLY SCREW	STL. STEEL
1	GLAZING BEAD 6063-T6 (9/16")	ALUM
2	LEAD STYLE 6063-T6 (9/16")	ALUM
3	INTERLOCK STILE - MOVING PANEL 6005-T5 (9/16")	ALUM
4	TOP RAIL 6063-T6 (9/16")	ALUM
5	BOTTOM RAIL - MOVING PANEL 6063-T6 (9/16")	ALUM
6	INTERLOCK STILE - FIXED PANEL 6005-T6 (9/16")	ALUM
7	FIXED PANEL RETAINING CLIP 6063-T6	ALUM
8	FRAME HEAD 6063-T6	ALUM
9	FRAME SILL 6063-T6	ALUM
10	FRAME JAMB 6063-T6	ALUM
11	OXO ADAPTOR 6005-T5	ALUM
13	OXO REINFORCEMENT 6005-T5	ALUM
14	FIXED PANEL STILE 6063-T6 (9/16")	ALUM
15	XX ADAPTOR 6005-T5	ALUM
17	FRAME HEAD POCKET COVER 6063-T6	ALUM
18	FRAME SILL POCKET COVER 6063-T6	ALUM
25	WEATHERSEAL SEALANT (WS001) DOW 795	SILICONE
27	GLAZING SPACER	-
28	GASKET, EPDM CLOSED CELL FOAM (9/16" STRUCTURAL GLAZING)	EPDM
29	GASKET, EPDM CLOSED CELL FOAM (1-5/16" GLAZING)	EPDM
30	WEDGE 70±5 EPDM (1-5/16" GLAZING)	EPDM
31	BACKER ROD - CLOSED CELL EXTRUDED FOAM	POLYETHYLENE
34	SHIM	-
35	SETTING/EDGE BLOCK	PLASTIC
41	ROLLER ASSM.	STL. STEEL
42	REACTION CLIP 6005-T5	ALUM
43	TOE ANCHOR 6005-T5	STEEL
49	BOTTOM RAIL - FIXED PANEL 6063-T6 (1-5/16")	ALUM
51	I.G. GLAZING BEAD 6063-T6 (1-5/16")	ALUM
52	I.G. FIXED PANEL STILE 6063-T6 (1-5/16")	ALUM
53	I.G. INTERLOCK STILE - MOVING PANEL 6063-T6 (1-5/16")	ALUM
54	I.G. TOP RAIL 6063-T6 (1-5/16")	ALUM
55	I.G. LEAD STILE 6063-T6 (1-5/16")	ALUM
56	I.G. BOTTOM RAIL - MOVING PANEL 6063-T6 (1-5/16")	ALUM
57	INTERLOCK STILE - FIXED PANEL (1-5/16")	ALUM
58	BOTTOM RAIL - FIXED PANEL 6063-T6 (9/16")	ALUM

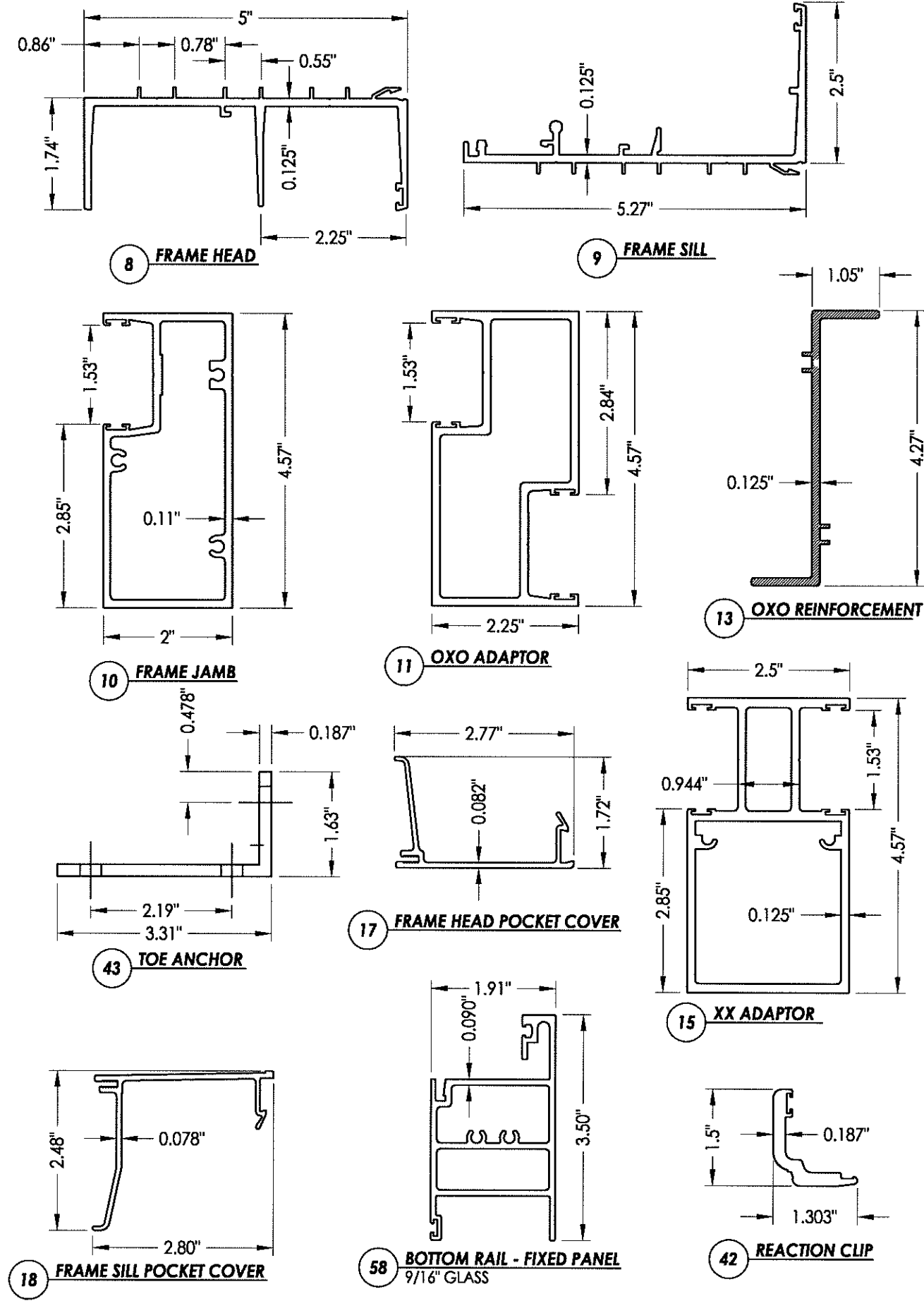

Documents Prepared By: **RW BUILDING CONSULTANTS, INC.**  
 P.O. Box 230 Valrico FL 33595  
 Phone No.: 813.659.9197  
 Florida Board of Professional Engineers  
 Certificate of Authorization No. 9813  
 Lyndon F. Schmidt, P.E. No. 43409

PRODUCT: SLIDING GLASS DOOR

PART OR ASSEMBLY: BILL OF MATERIALS & COMPONENTS

NO.	DATE	BY

REVISIONS

DATE: 02/26/08  
 SCALE: N.T.S.  
 DWG. BY: JK  
 CHK. BY: LFS  
 DRAWING NO.: FL-15903.15  
 SHEET 12 OF 12

© 2012 R.W. BUILDING CONSULTANTS INC.